

CHILD'S POOL OR SHOWER JACKET

SUPPLIES:

Bath Towel	Ellegante/Imagine or Evolve	3" wide Olfa ruler
Embroidery designs	Assorted trims	Double eyed needle
Gathering foot	Ruffler foot	Walking foot
Designer's Gallery	Clear water soluble stabilizer	KK2000 or 505 adhesive spray
Metal Sewing gauge	Magnetic pin caddy/Long pins	Wonder Tape
Tube turners	Chalko marker (asst. colors)	Bent scissors
Rotary Cutter		

Fold towel in half, lengthwise. If the towel has borders, match and pin borders to keep them lined up. Fold towel in half again in the opposite direction. Place a pin in the top center corner on the fold, to mark the center of the towel.

The straight side of the neck template is placed on the side fold of the towel, with the top of the template on the top fold. Using the Chalko marker, mark the angled side of the template. Turn the towel over and mark the angle on the other side. Mark along the long fold of the towel with the Chalko marker to mark the center cutting line for the front opening. Open the towel and cut up the front, on ONE LAYER ONLY, and cut out the neck opening.

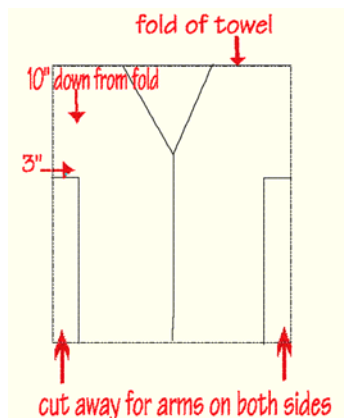

SLEEVES:

Place the towel on a flat surface and make sure the borders and/or bottom of the towel line up evenly. Measure down 10" from the top fold and mark with a pin on both sides. Measure in 3" or place a 3" wide Olfa ruler just beneath the pin and draw a line down the inside of the ruler with the Chalko marker, marking both sides. Pin the towel together so it's even and straight and cut away the excess toweling. This will form the sleeves.

Once the front, neck and sleeves have been cut out, open the towel and serge around cut edges. DO NOT sew together at this time, because it will be much easier to embroider and/or decorate when laying flat.

EMBROIDERY: Choose embroidery designs and print out full size templates from Designer's Gallery. Place the templates in various locations on the towel until you

decide on a good arrangement.

Hint: When embroidering on terry cloth (toweling), always place clear stabilizer on top before embroidering. Your stitches will look better, they won't "sink" into the terry cloth, and the loops from the terry cloth won't poke through your embroidery. Use this method whenever you appliqué on terry cloth, fleece, or any plush fabric. The clear stabilizer also makes it easier to trim away appliqué fabric in an embroidery design, because it places a barrier between the toweling and the appliqué fabric to be cut away.

TRIM:

Adding trim to the jacket will allow you to use some of the fabric stash in your closet, or give you the opportunity to buy more fabric! When adding trims on the front and neck area of the jacket, cut the fabric on the bias. The fabric will go around the curves of the neck easier and give the jacket a neat edge. Using the Gathering Foot or Ruffler for the trim on the bottom of the jacket and/or the sleeves will dress it up for the little girl in your life.

Cut the fabric strips 2" to 2 ½" wide and sew them on from the back, or inside, of the jacket. Fold the fabric to the front and press, then fold over approximately ½" on the raw edge of the binding, and press. Use the metal Sewing Gauge to determine an accurate amount to turn. Turn the binding to the front side of the jacket, pin in place and top stitch. This is also a great place to use all those decorative stitches. An easy way to keep the folded edges in place is to use Wonder Tape. It holds the fabric, doesn't gum up needles, and washes away in the first washing.

FINAL TOUCHES:

A closure of some kind can be added, such as a button, ties made from the extra trim, or even a dot of Velcro. Ties are easy to make, using the tube turner tool.